

SHELTERWORLD 5' x 6'-6" Round Style ASSEMBLY INSTRUCTIONS

PLEASE READ ENTIRE INSTRUCTION MANUAL BEFORE ERECTING YOUR SHELTER

1. Assemble Rafters

Select a level area on which to locate your poly shelter. This is important for the straightness and stability of the shelter.

Locate the rafter pipes. The bottoms of both pieces are not swaged. The top end of one is swaged and the top of the other section is not swaged (drawing 1-A). Connect one of each side piece together to make one complete rafter (drawing 1). Secure by fastening a Tek Screw into the connection being sure not to place the screw at the top where it will come in contact with the cover (drawing 1-A). The Tek Screws are self drilling, no "pilot hole" is needed. Assemble all the rafters using the same procedure.

DRAWING 1

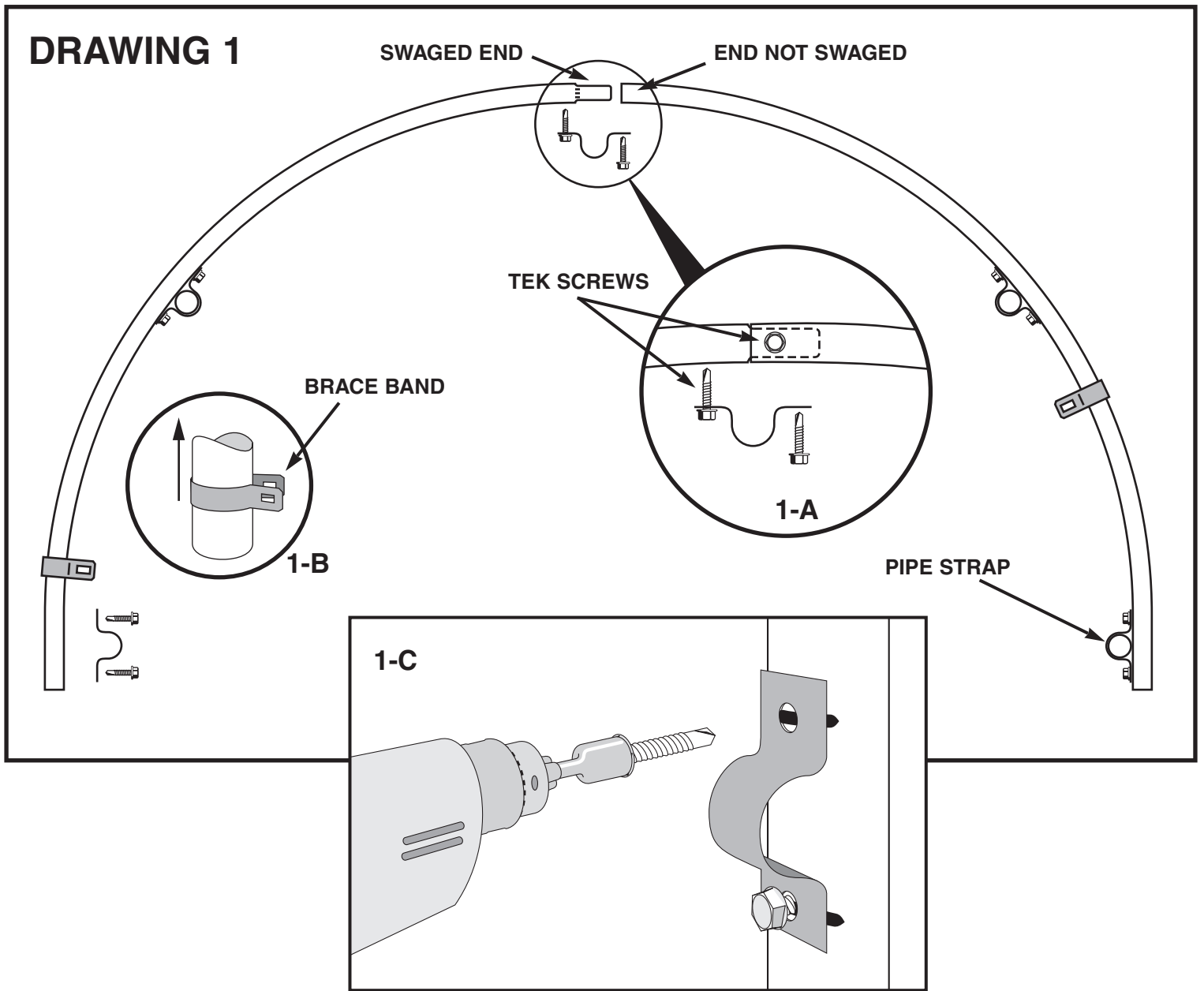

1. Assemble Rafters (continued)

Next install the pipe straps that hold the purlins on the inside of the rafters using Tek Screws, leaving the screws loose for easier insertion of the purlins during a later step (drawing 1-C). You will find the pipe strap locations already marked on the rafters.

Your model has 5 pipe straps per rafter, including one for the ridgepole (see drawing 1).

NOTE: Before installing the bottom pipe straps on the first and last rafters, slide the brace bands onto both sides of the first and last rafters, leaving them loose (drawing 1-B). Continue installing all remaining pipe straps.

Rafter Spacing:

On a Standard 5' x 6'-6" x 8' shelter the rafter spacing is 48", but if your adding rafters for snow load, etc., please determine rafter spacing using the following method.

Multiply the length of the shelter by 12 to arrive at the total length of the shelter in inches. Next divide the total inches by the number of rafters minus 1 to allow for the first rafter. This will give you the distance in inches from center to center from one rafter to the next.

Example: Using a 36' long shelter as an example.

36 feet x 12 inches equals 432 inches. ($36' \times 12" = 432"$)

A 36' shelter comes with 10 rafters minus 1 (to allow for the first rafter) equals 9 ($10-1=9$).

Dividing 432 inches by the 9 rafters equals 48 inches on center ($432" \div 9" = 48"$).

2. Stand Rafters Up and Install Struts and Purlins

This step shows how to stand the rafters up and connect the purlins. One or two people will be needed for this step. This can also be made easier if the first rafter is stood up and braced with two-by-fours and rope (drawing 2).

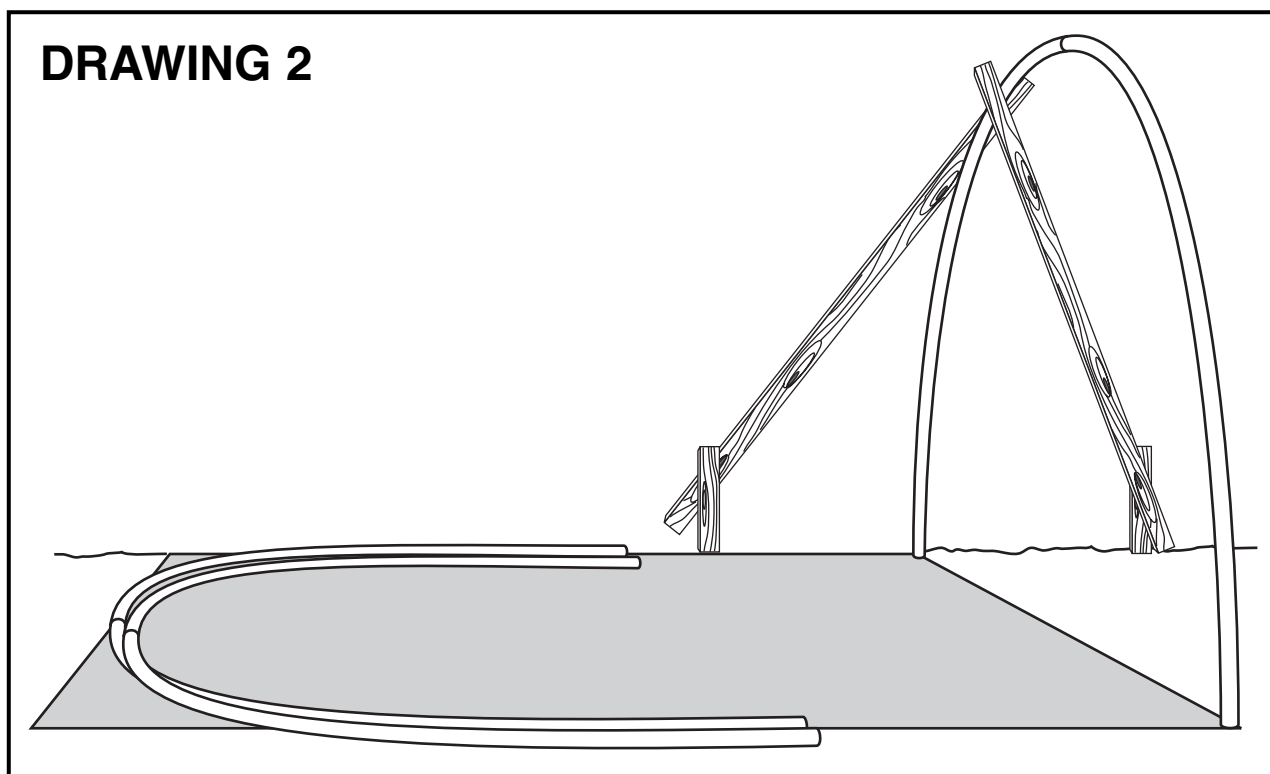

2. Stand Rafters Up and Install Struts and Purlins (continued)

Space the first two rafters the correct distance apart and slide the purlins into the pipe straps. Slide a brace band on the bottom purlin between the first and second rafter and leave it loose (drawing 3). Tighten Tek Screws on the first rafter. Add a third screw through the pipe straps into the purlin to hold the purlin on the first rafter securely in place (drawing 3-A). Make sure the purlin does not protrude out from under the pipe strap beyond the first and last rafters or it may rub against the end panel (drawing 3-A).

Measure in from the outside of the first pipe strap the number of inches you determined for your rafter spacing, then locate the second rafter. Tighten down the pipe strap Tek Screws.

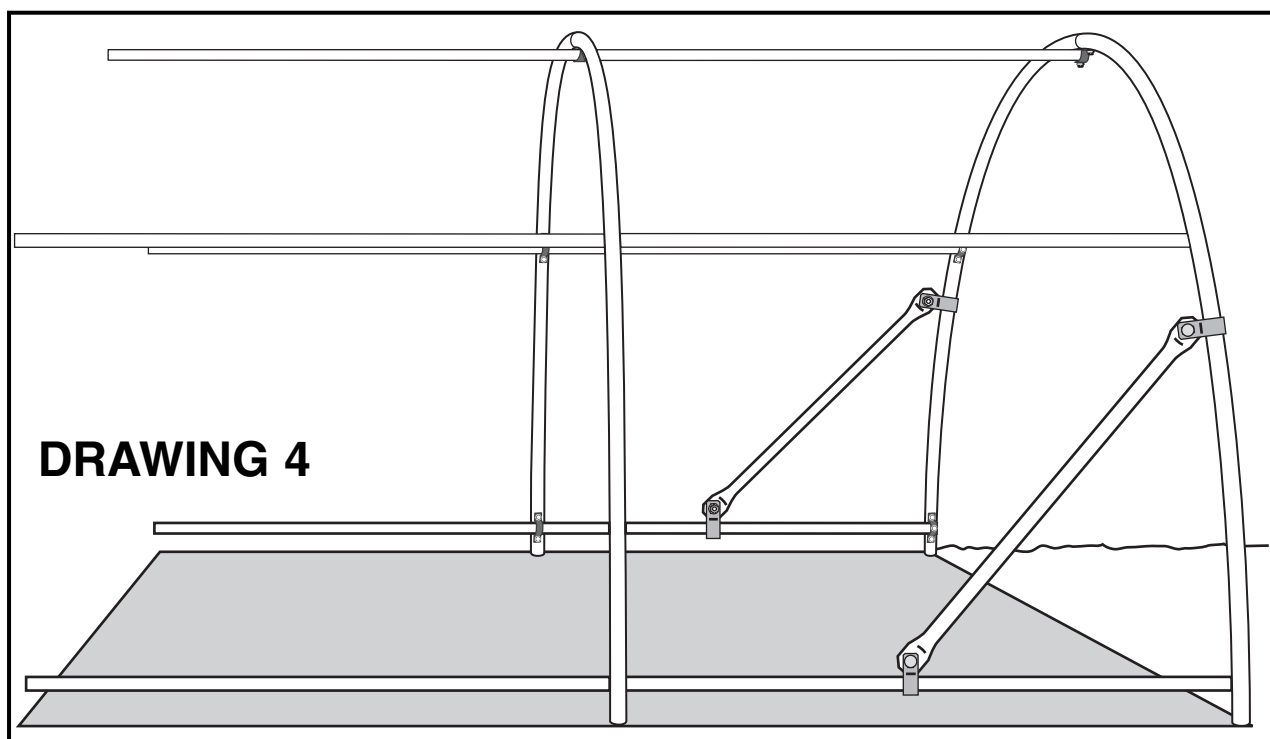
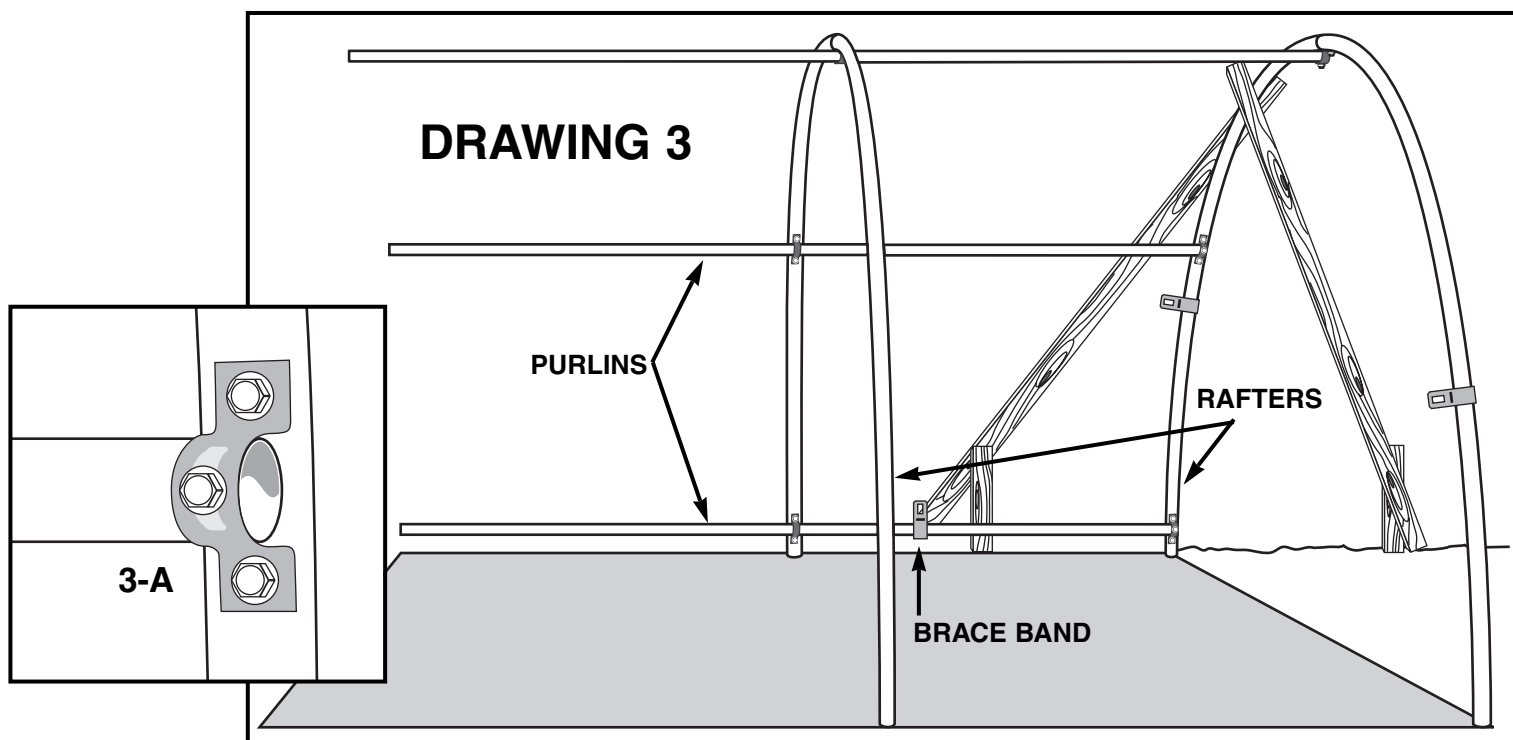

2. Stand Rafters Up and Install Struts and Purlins (continued)

Locate the two 5' struts and attach one end to the brace band on the first rafter with a 1-1/2" carriage bolt and nut, leaving the bolt loose. Connect the other end of the 5' strut, to the brace band on the bottom purlin. Position the strut so that it forms a triangle and tighten the brace bands (drawing 4).

Continue assembling until all the rafters and purlins are in place. On longer models, join the multiple sections of the purlin with Tek Screws. Some connections may be between rafters and others may be located directly on a rafter. If the connection is located at a rafter, connect it by screwing through the pipe strap with a Tek Screw. Mid-rafter connections may be secured by fastening a Tek Screw into the connection. Attach the two remaining 7' struts on the last two rafters in the same manner as the first rafters.

3. Square the Corners and Tape Sharp Edges

Once all the rafters, struts, and purlins have been connected, position the structure exactly where you want it located. Do not add the third Tek Screw in the pipe straps on the other rafters until you have re-checked the spacing between all the rafters and are sure that each rafter is standing up straight and spaced correctly. Add the third Tek Screw to the remaining pipe straps. Square the corners and line up all rafters using a straight line (drawing 5). Check for any sharp edges on the frame and file them smooth so they will not cut the cover. Apply two layers of heavy duct tape on all pipe connections that may come into contact with the cover (drawing 5-A).

4. Anchor the frame securely using one of our recommended anchoring systems (see page 11).

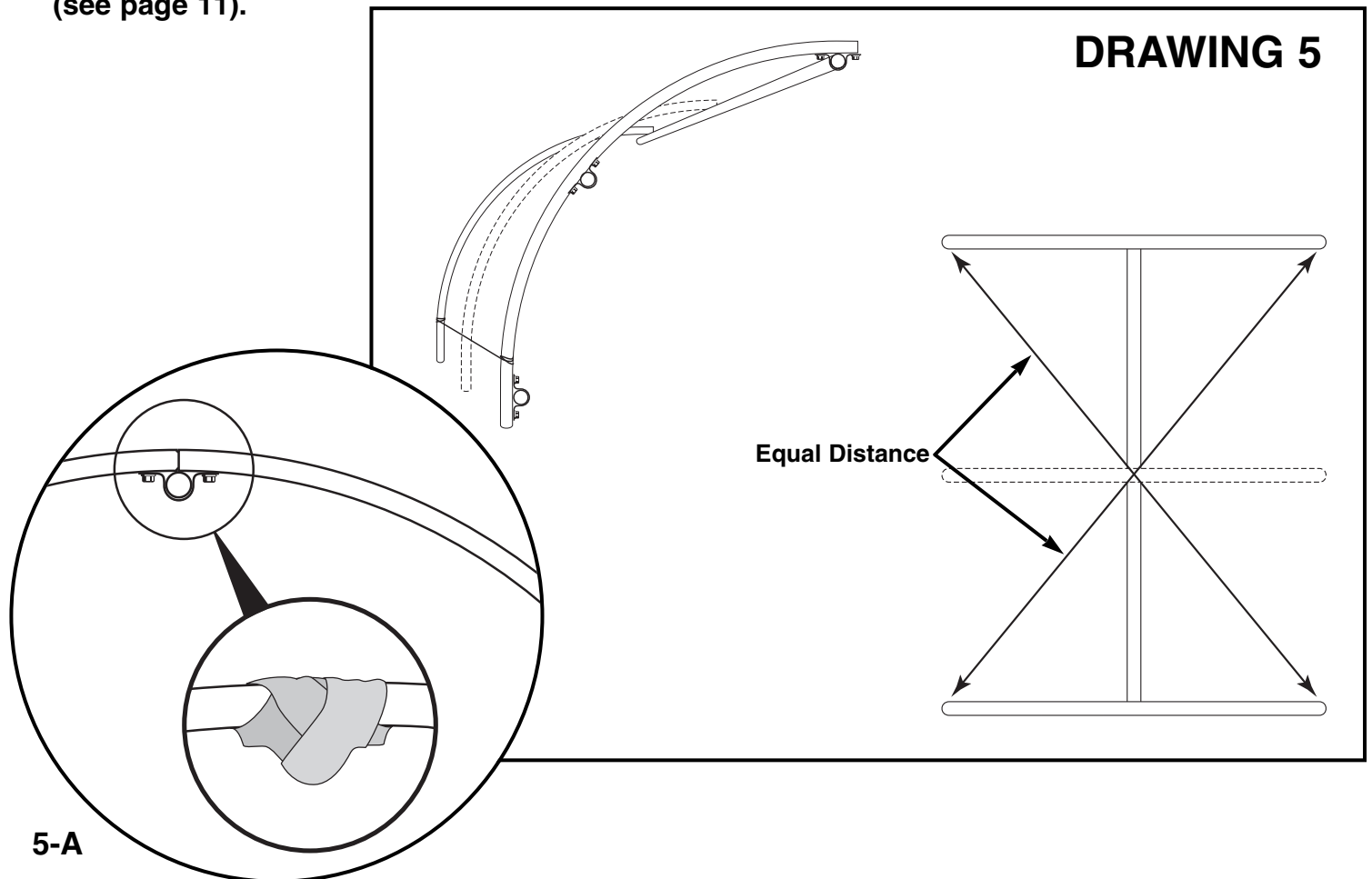

5. Install End Panels

Locate end panels and end conduit. Slide conduit into hem at the bottom of the plain end panel and position panel so the bottom edge is just touching the ground. Next, drill a 5/16" hole through the last rafter using the holes in the end conduit as a guide. Then fasten the conduit to the outside of the last rafter with a carriage bolt and nut (drawing 6).

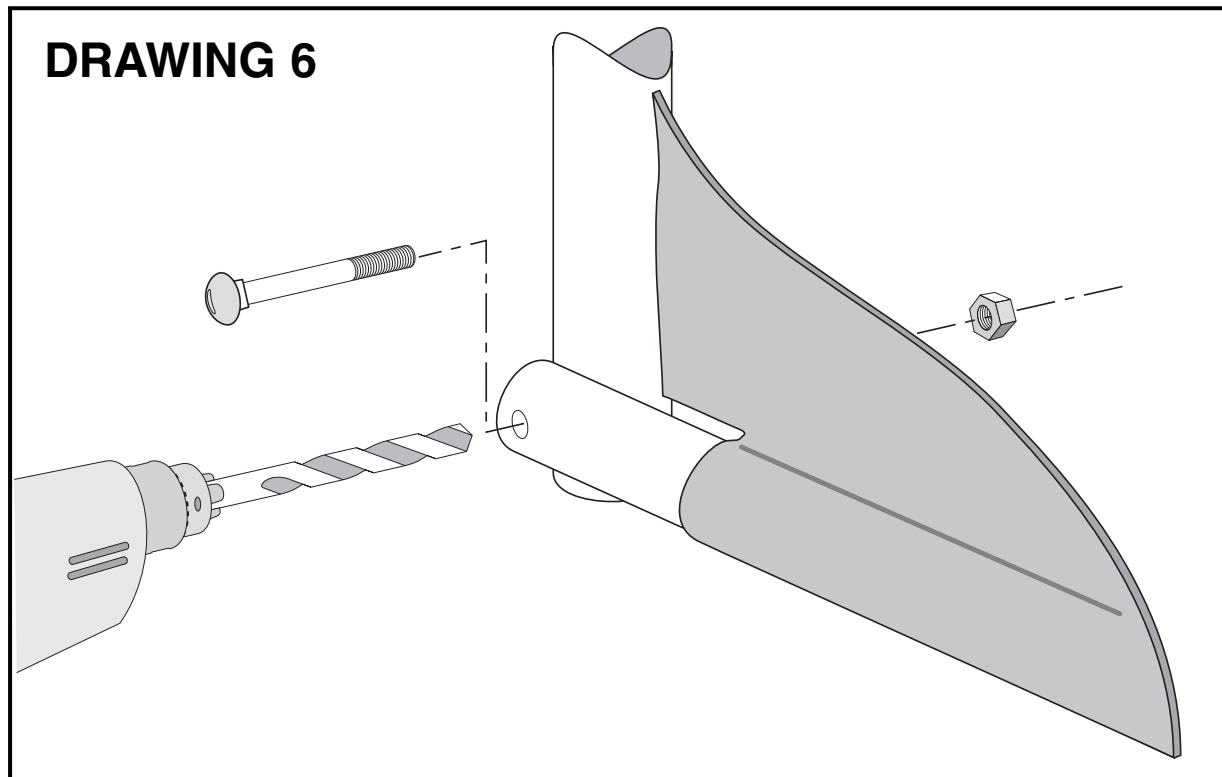

While standing inside the shelter, start at the peak of the end rafter and pull the end panel over the top of the rafter so the material edge is on the inside of the rafter. Secure the panel in place at the top center with a fabric clip. Move outward in both directions, placing one fabric clip every 24" (drawing 7).

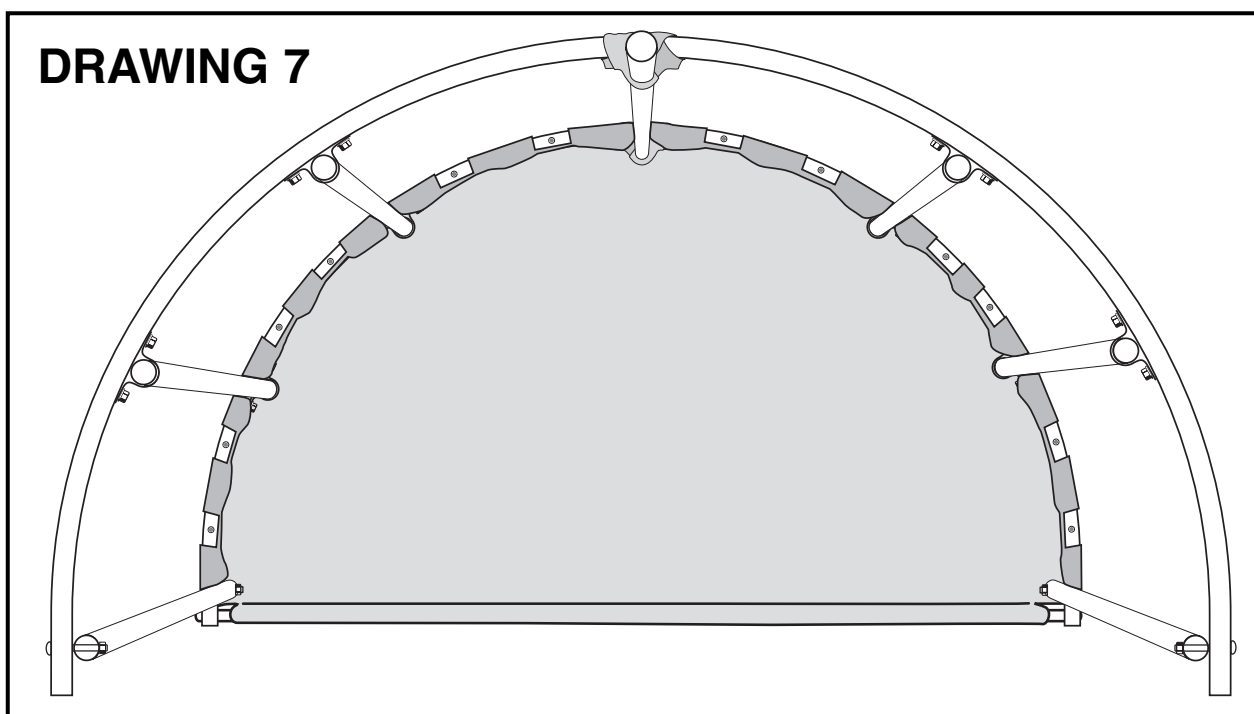

5. Install End Panels (continued)

For installing the zippered end panel, follow the same steps, only do not insert the conduit through the door section(s), only the side portions of the end panel. On models with a single zipper door the conduit will not be placed in the hem (drawing 8).

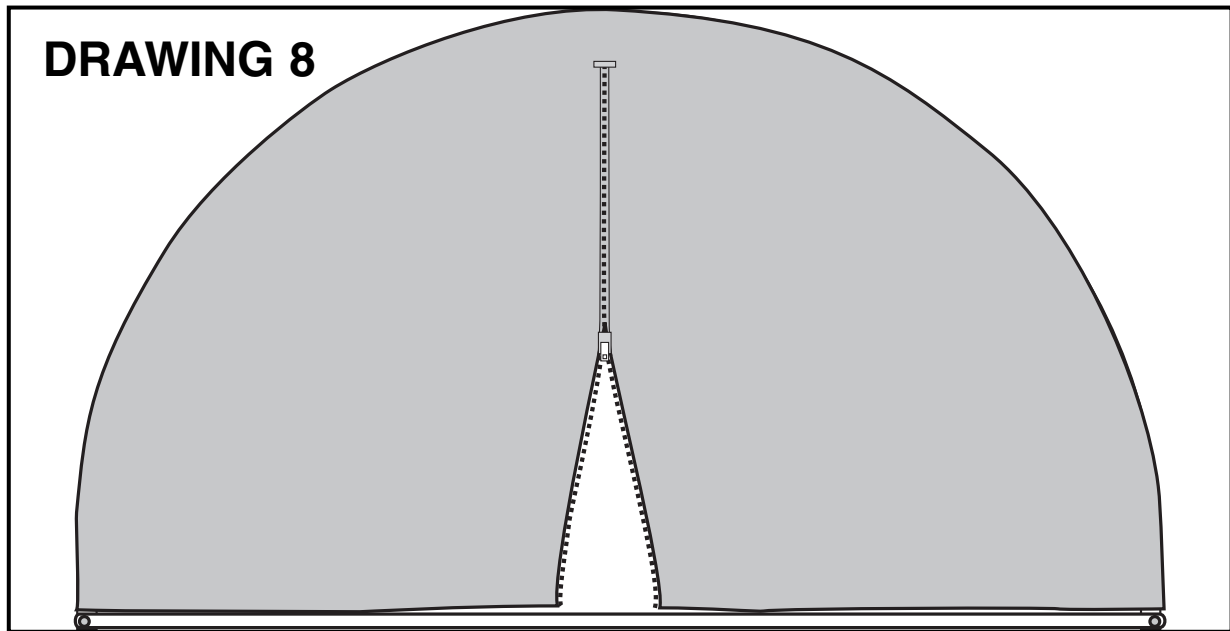

6. Assemble Main Cover

Unpack main cover and unfold it completely with the white side or inside surface facing up. The ends that have black straps in the hems correspond to the front and back of the shelter. Slide the cover conduit into the hem openings that are located about 9" from the ends of the cover (drawing 9). On the larger units the cover can be pulled over the frame by attaching ropes to the cover conduit and pulling the ropes over the top of the shelter. Center the cover front to back and side to side.

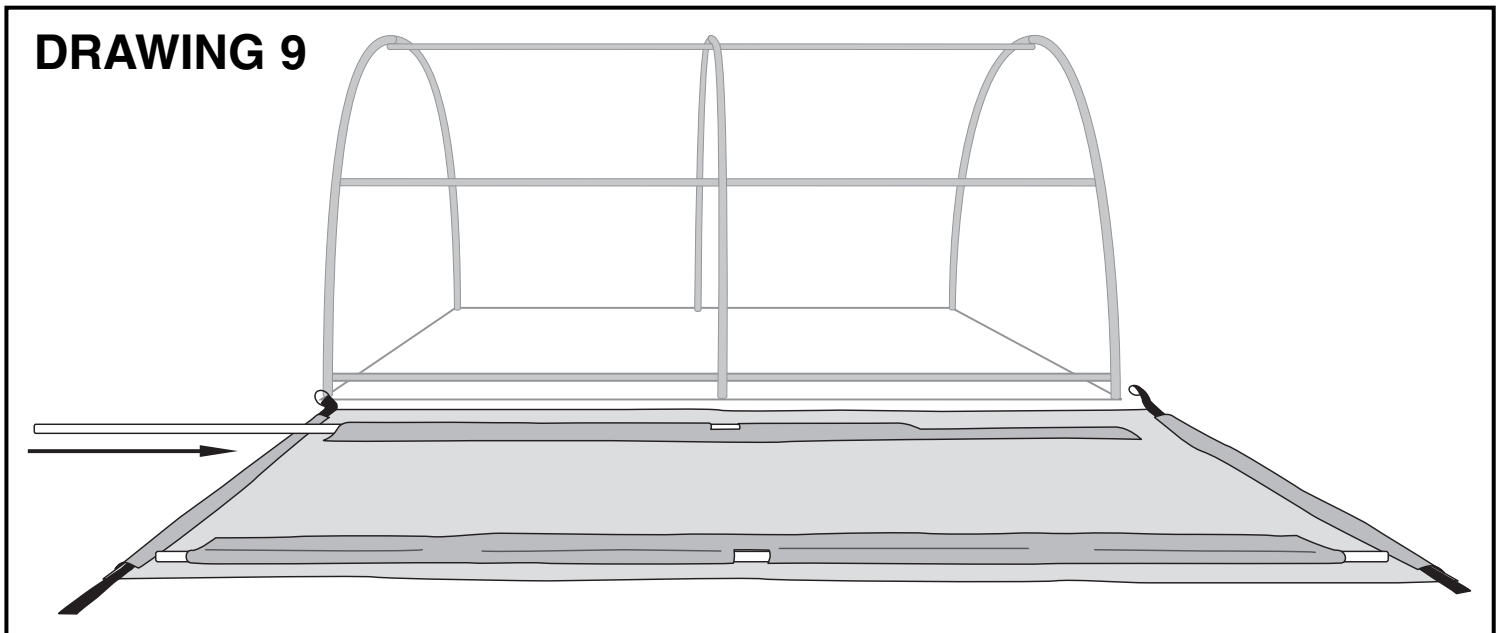

DO NOT ATTEMPT TO INSTALL COVER OR END PANELS ON A WINDY DAY, AS DAMAGE TO THE COVER OR END PANELS MAY RESULT!

7. Tighten Main Cover

In the front and rear hems, locate the end of the black straps with D-rings attached. Secure the D-rings to the end conduit with a Tek Screw 6" from the end (drawing 10 & 10-A).

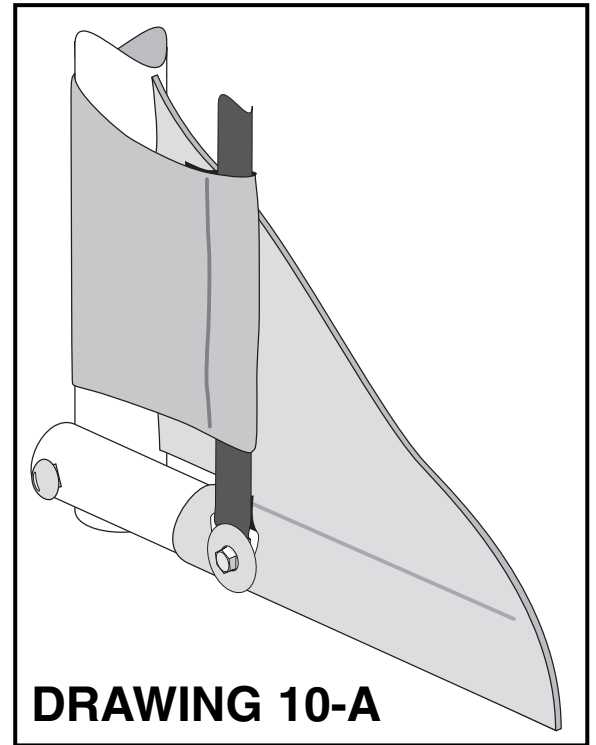
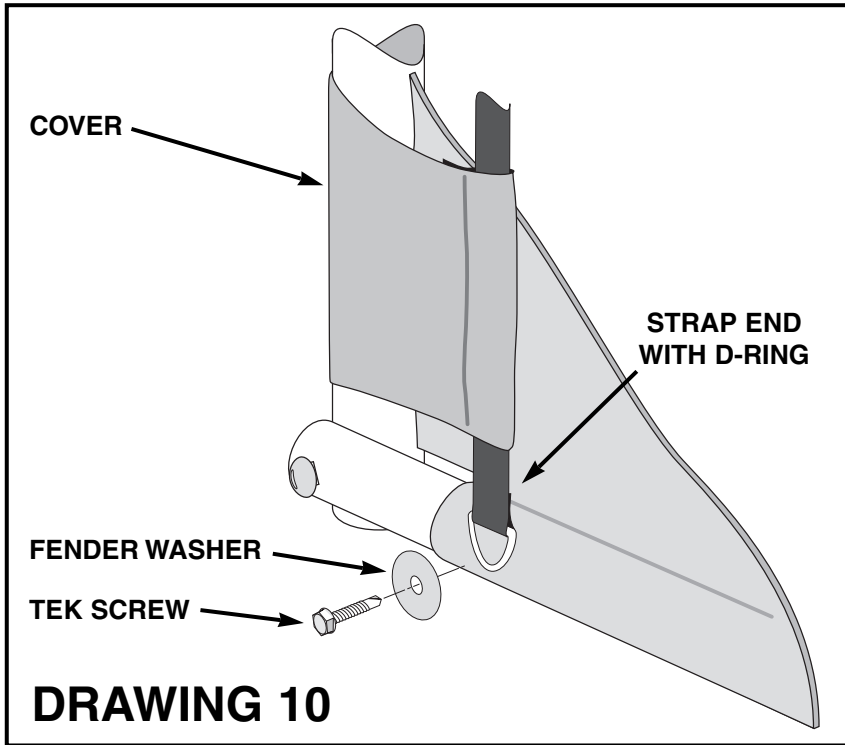

On the same side of the shelter, loop the black straps with D-rings over the cover conduit showing through the slots in the cover and secure D-rings to rafters with a fender washer and a Tek Screw 2" from the bottom of rafter (drawing 11 & 11-A).

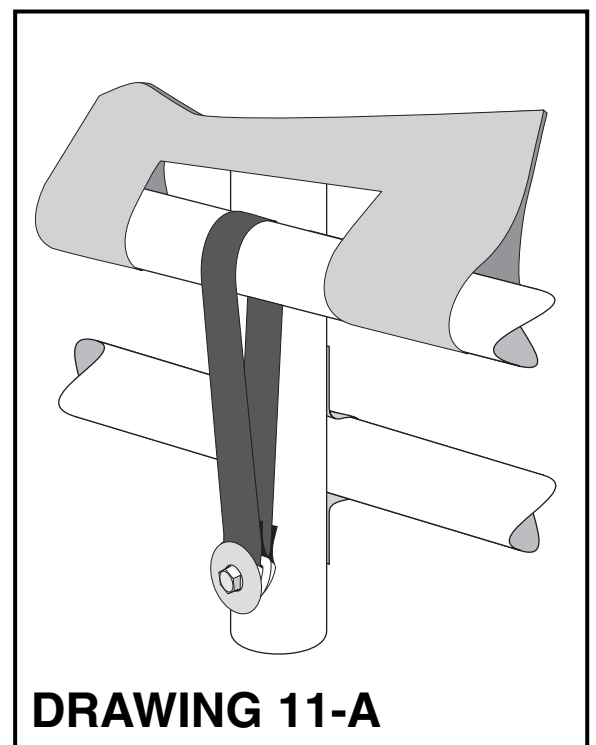
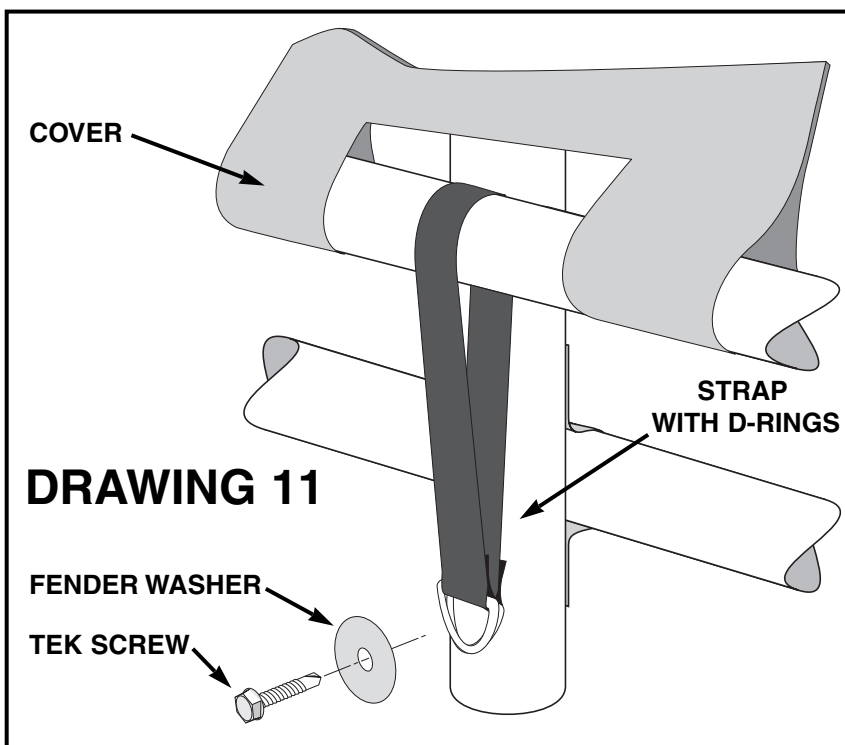

7. Tighten Main Cover (continued)

On the opposite side of cover with the plain strap end, fasten a ratchet onto the end conduit with a Tek Screw in the bottom hole of the ratchet, 6" from the end. Tighten strap by pulling manually. Cut excess strap leaving 12" in length. Feed the cover end strap through the center slot in the ratchet and tighten slightly (drawing 12).

On the same side of the shelter, locate the slots in the cover exposing conduit and fasten ratchets with a Tek Screw about 2" from the bottom of those rafters (drawing 13).

The ratchets are located on the same rafters to which the D-rings are attached, but on the opposite side of the shelter. Some models may have 2 consecutive rafters without ratchets.

For the center ratchets, loop the 3' straps over the conduit where the hem is cut out and feed both ends of the straps through the slot in the ratchets and tighten slightly (drawing 13).

Center the cover evenly from front to back. Tighten the outer ratchets first and then the inner ratchets. If the ratchets need to be released, open them completely and they will release. Excess strap can then be pulled through ratchets and re-tightened.

**COVER MUST BE KEPT TAUT.
CHECK AND ADJUST TENSION
PERIODICALLY.**

DRAWING 12

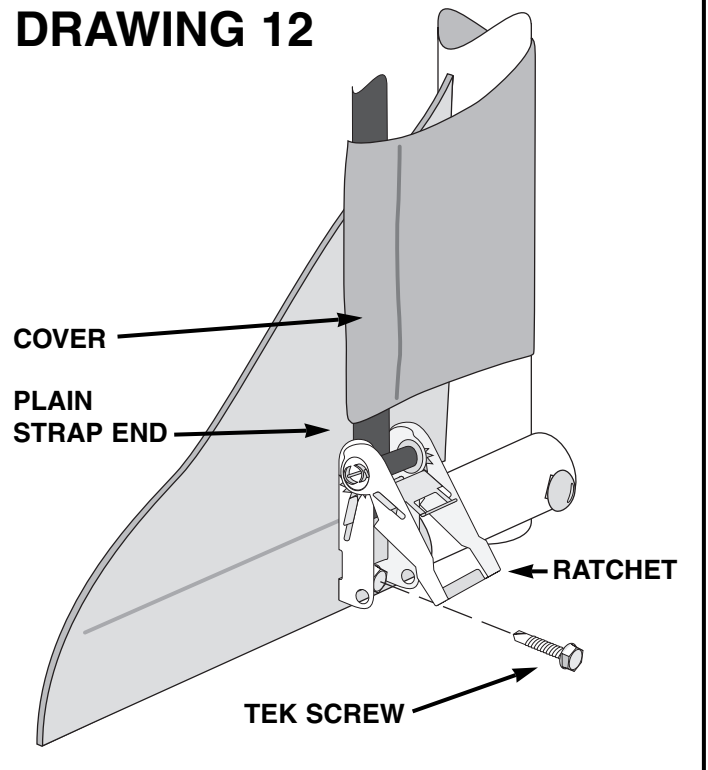

DRAWING 13

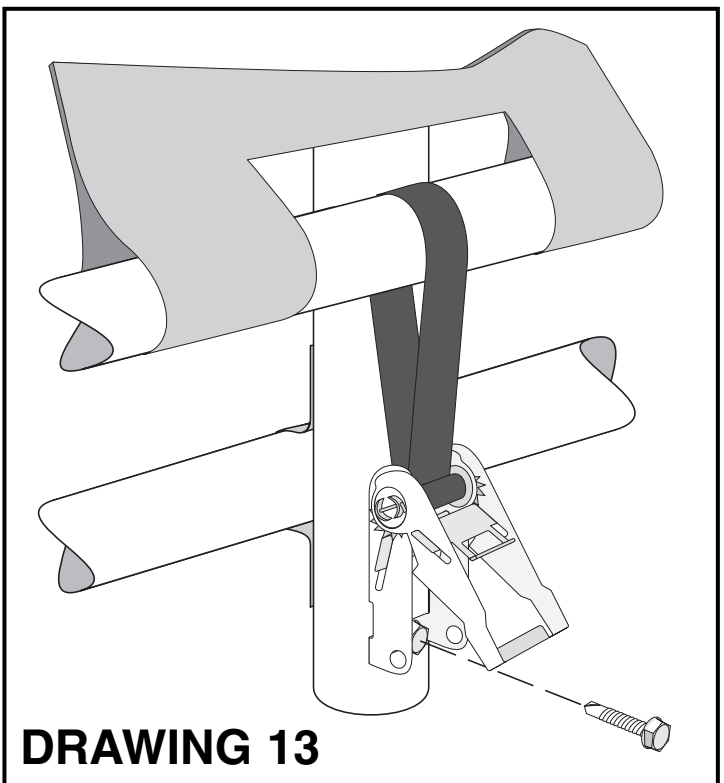

**IMPORTANT:
SNOW MUST NOT BE ALLOWED TO ACCUMULATE ON COVER.**

SHELTERWORLD 5' x 6'-6" Round Style PARTS ILLUSTRATION

BECOME FAMILIAR WITH THESE PARTS BEFORE ERECTING YOUR SHELTER

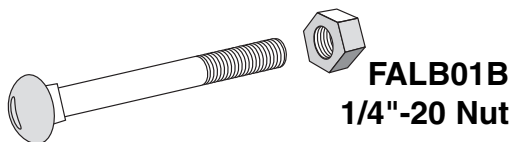

FALB01B
1/4"-20 Nut

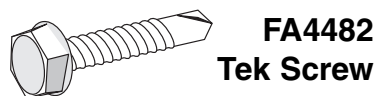

FA4482
Tek Screw

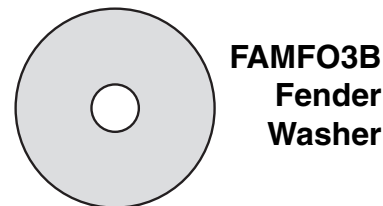

FAMFO3B
Fender
Washer

FAH007B
1/4" x 3" Carriage Bolt

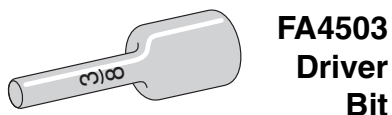

FA4503
Driver
Bit

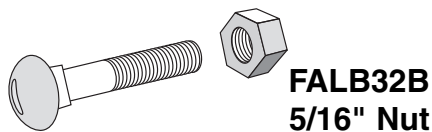

FALB32B
5/16" Nut

FAH317
5/16" x 1-1/2" Carriage Bolt

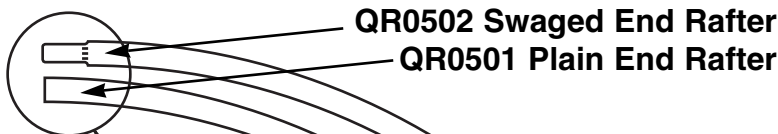

QR0502 Swaged End Rafter
QR0501 Plain End Rafter

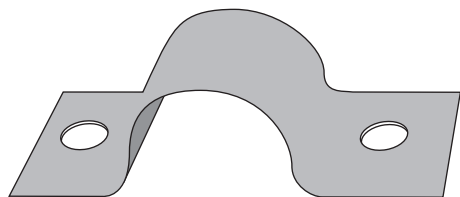

QH1070 Pipe Strap



Purlin/Cover Conduit



QPE005 End Panel Conduit

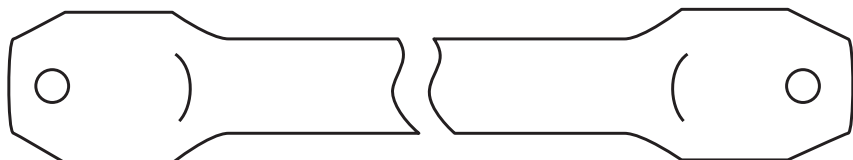

QH1304 - 5' Strut

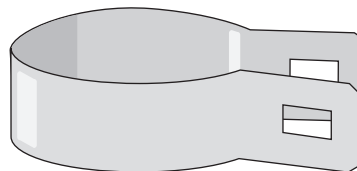
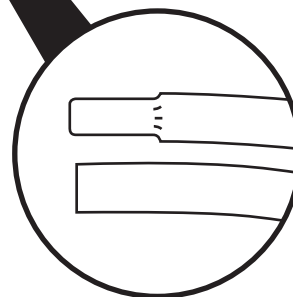

QH1078 Brace Band

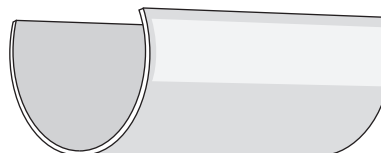

CC6212 Fabric Clip

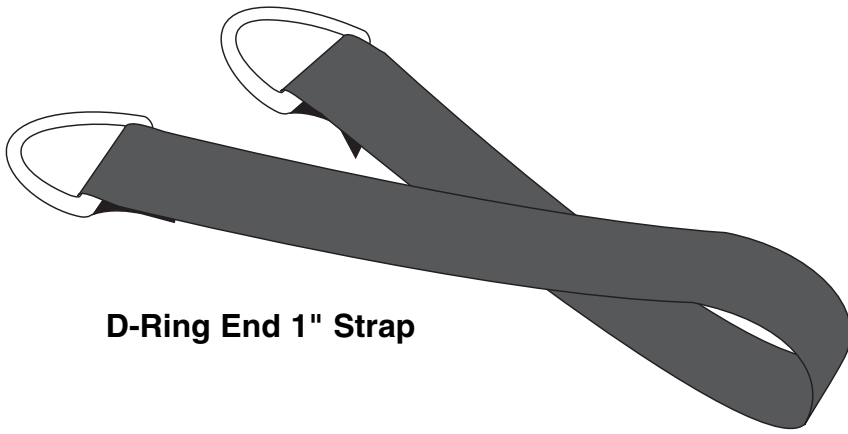

D-Ring End 1" Strap

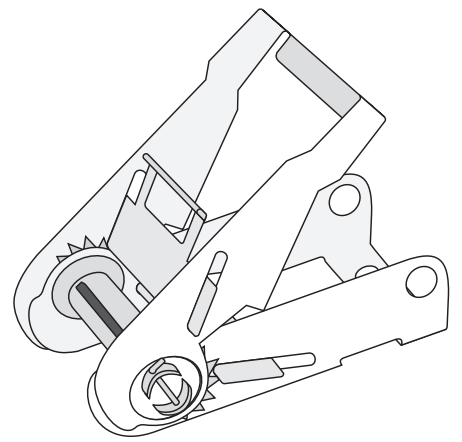

QH061 - 1" Strap Ratchet

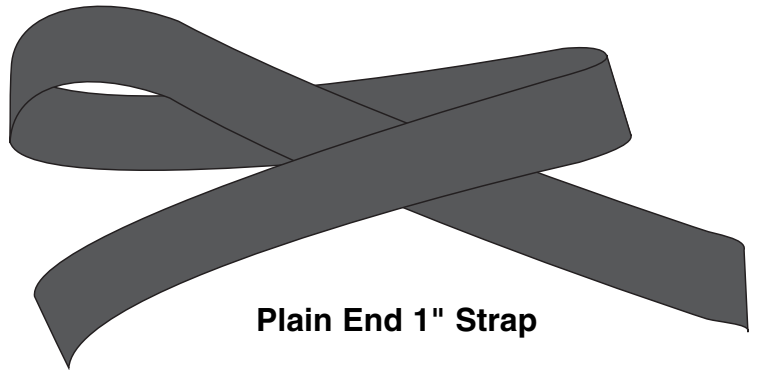

Plain End 1" Strap

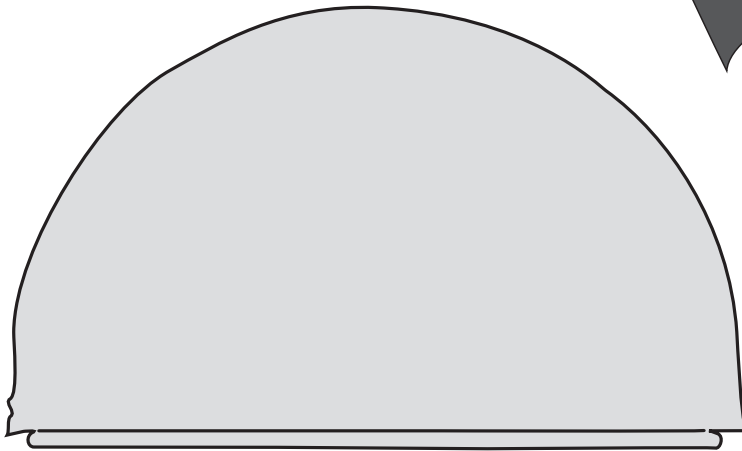

Plain End Panel

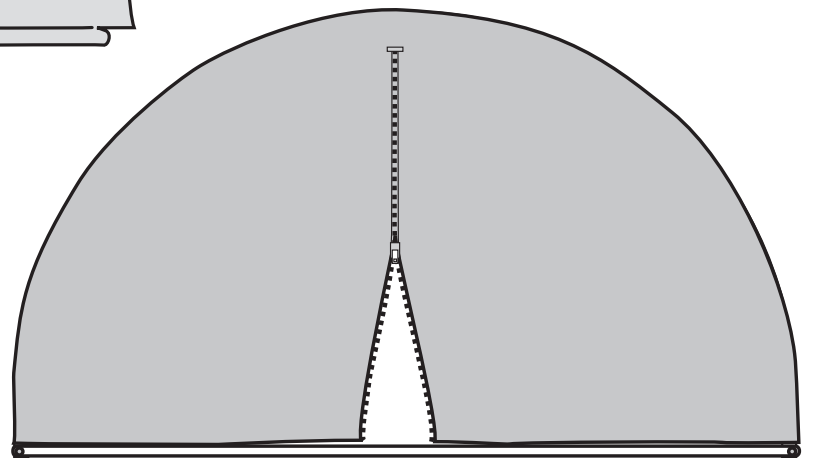

Zippered End Panel

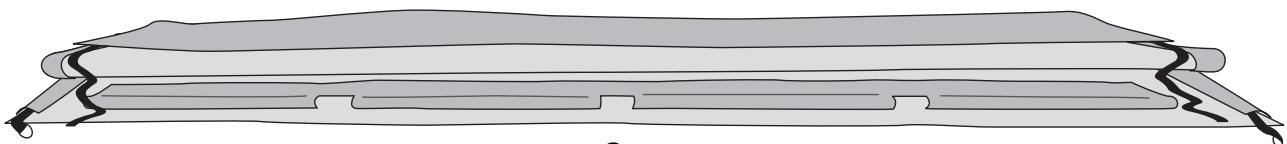

Cover

ANCHORING INSTRUCTIONS

At SHELTERWORLD we offer three different anchoring systems. Anchoring systems are designed to ensure that your shelter is anchored safely and securely. The type of system shipped with your shelter was selected because of the size of your shelter and the type of surface to which you are securing your shelter.

Type 1: Earth Auger Anchor assembly

Includes a 30" Earth Auger Anchor, a 6" Turnbuckle and a securing Clamp Band Assembly.

This type anchor assembly should be placed at each corner and at 1 side of each inside rafter. It is recommended that you place one on every even numbered rafter on the right side and every odd numbered rafter on the left side of your building.

1. Place 1 Earth Auger Anchor, 1 Turnbuckle, and 1 Clamp Band Assembly (including 1 nut and 1 bolt) where they will be installed.
2. Screw the Earth Auger Anchor into the ground approximately 20"–26", making sure the eye of the Auger is within 7"–8" of the rafter to which it will be attached. Note: The placement of the Earth Auger Anchor is not critical, as long as the Turnbuckle will reach from the Anchor to the rafter it will be supporting.
3. Unscrew the "hook" and the "eye" ends of the Turnbuckle to lengthen it approximately halfway. Attach the "hook" of the Turnbuckle through the "eye" of the Earth Auger Anchor.
4. Spread the Clamp Band and place around the rafter. Squeeze the Clamp Band back together and place the "eye" of the Turnbuckle in the Clamp Band opening and secure with the bolt and nut. Slide Clamp Band as high up the rafter as it will go, then tighten the nut on the bolt.
5. Turn Turnbuckle until taut.

Type 2: Shelter Bracket

Includes a Bracket and a 5-1/2" Cement Wedge Anchor.

1. Place a Bracket and a Cement Wedge Anchor next to each rafter end.
2. Place the Bracket over the bottom purlin and mark the center of the hole in the Bracket on the cement.
3. Drill hole in the cement at least 4-1/2" deep.
4. Place Wedge Anchor into hole, then fit Bracket over bottom purlin and threaded portion of Wedge Anchor. Secure Wedge Anchor with nut and washer.

Type 3: Duck Bill Earth Anchors

Includes a complete assembly plus U-bolt assembly.

1. Place a Duck Bill Earth Anchor next to each side of all rafters.
2. Using the Drive Steel drive the Duck Bill into the ground, making sure the loop attached to the attached to the cable is left 6" above ground, insert steel levering bar through loop, lift and lock anchor.
3. **Spread rafter clip over rafter, insert through bolt through cable loop, pull clip up and tighten.**